

Installation Note

Extended Frequency Range Upgrade Kit

For E8362B PNA Series Microwave Network Analyzers WITHOUT the Configurable Test Set Option

Network Analyzer Model Number	Upgrade Kit Part Number	Frequency Extension
E8362B	E8362-60109	20 GHz to 40 GHz



Agilent Technologies

Agilent Part Number: E8362-90004

Printed in USA May 2003

© Copyright 2003 Agilent Technologies, Inc. All rights reserved.



E8362-90004

Notice

THE MATERIAL CONTAINED IN THIS DOCUMENT IS PROVIDED “AS IS,” AND IS SUBJECT TO BEING CHANGED, WITHOUT NOTICE, IN FUTURE EDITIONS. FURTHER, TO THE MAXIMUM EXTENT PERMITTED BY APPLICABLE LAW, AGILENT DISCLAIMS ALL WARRANTIES, EITHER EXPRESS OR IMPLIED WITH REGARD TO THIS MANUAL AND ANY INFORMATION CONTAINED HEREIN, INCLUDING BUT NOT LIMITED TO THE IMPLIED WARRANTIES OF MERCHANTABILITY AND FITNESS FOR A PARTICULAR PURPOSE. AGILENT SHALL NOT BE LIABLE FOR ERRORS OR FOR INCIDENTAL OR CONSEQUENTIAL DAMAGES IN CONNECTION WITH THE FURNISHING, USE, OR PERFORMANCE OF THIS DOCUMENT OR ANY INFORMATION CONTAINED HEREIN. SHOULD AGILENT AND THE USER HAVE A SEPARATE WRITTEN AGREEMENT WITH WARRANTY TERMS COVERING THE MATERIAL IN THIS DOCUMENT THAT CONFLICT WITH THESE TERMS, THE WARRANTY TERMS IN THE SEPARATE AGREEMENT WILL CONTROL.

Getting Assistance from Agilent

By internet, phone, or fax, get assistance with all your test and measurement needs.

Online assistance: www.agilent.com/find/assist		
United States <i>(tel)</i> 1 800 452 4844	Latin America <i>(tel)</i> (305) 269 7500 <i>(fax)</i> (305) 269 7599	Canada <i>(tel)</i> 1 877 894 4414 <i>(fax)</i> (905) 282-6495
Europe <i>(tel)</i> (+31) 20 547 2323 <i>(fax)</i> (+31) 20 547 2390	Australia <i>(tel)</i> 1 800 629 485 <i>(fax)</i> (+61) 3 9210 5947	New Zealand <i>(tel)</i> 0 800 738 378 <i>(fax)</i> (+64) 4 495 8950
Japan <i>(tel)</i> (+81) 426 56 7832 <i>(fax)</i> (+81) 426 56 7840	Singapore <i>(tel)</i> 1 800 375 8100 <i>(fax)</i> (65) 836 0252	Malaysia <i>(tel)</i> 1 800 828 848 <i>(fax)</i> 1 800 801 664
India <i>(tel)</i> 1 600 11 2929 <i>(fax)</i> 000 800 650 1101	Hong Kong <i>(tel)</i> 800 930 871 <i>(fax)</i> (852) 2506 9233	Taiwan <i>(tel)</i> 0800 047 866 <i>(fax)</i> (886) 2 25456723
Philippines <i>(tel)</i> (632) 8426802 <i>(tel)</i> (PLDT subscriber only) 1 800 16510170 <i>(fax)</i> (632) 8426809 <i>(fax)</i> (PLDT subscriber only) 1 800 16510288	Thailand <i>(tel)</i> (outside Bangkok) (088) 226 008 <i>(tel)</i> (within Bangkok) (662) 661 3999 <i>(fax)</i> (66) 1 661 3714	People’s Republic of China <i>(tel)</i> (preferred) 800 810 0189 <i>(tel)</i> (alternate) 10800 650 0021 <i>(fax)</i> 10800 650 0121

About the Upgrade Kit

Products affected	E8362B without Option 014, Configurable Test Set
Installation to be performed by	Agilent service center or personnel qualified by Agilent
Estimated installation time	1 hour
Estimated verification time	5 minutes
Estimated calibration adjustment time	45 minutes

If you need assistance, refer to [“Getting Assistance from Agilent”](#) on page 2.

Description of the Upgrade

This upgrade kit is used to extend the frequency range of the:

- E8362B PNA microwave network analyzer from 20 GHz to 40 GHz

Items Included in the Upgrade Kit

Check the contents of your kit against the following list. If any item is missing or damaged, contact Agilent Technologies. Refer to [“Getting Assistance from Agilent” on page 2](#).

Table 1 Option 040 Upgrade Kit (E8362-60109) to Extend the E8362B to 40 GHz

Ref. Desig.	Description	Qty	Part Number
Parts for all analyzer options (except Option 014)			
N/A	Installation note (this document)	1	E8362-90004
N/A	License key certificate	1	5964-5136
N/A	Model number nameplate (for 40 GHz analyzer, E8363B)	1	E8363-80002
A21	SOMA 50	1	5087-7130
A23	Channel R1 detector	2	5087-7133
A24	Channel R2 detector		
A25	Test port 1 coupler	2	5087-7518
A26	Test port 2 coupler		
A27	Channel A first converter (mixer)	2	5087-7122
A30	Channel B first converter (mixer)		
N/A	Machine screw M3.0 x 18 (for attaching A23 and A24 detectors)	4	0515-0666
N/A	Machine screw M3.0 x 30 (for attaching SOMA 50)	4	0515-1349
N/A	Ribbon cable, A21 SOMA 50 to A16 test set motherboard	1	8121-0818
N/A	Cable, wrapped wire, detectors to A16 test set motherboard	2	E7340-60075
N/A	Test set deck front panel	1	E8364-00014
W1	A12 source 20 to A21 SOMA 50	1	E8364-20036
W2	A21 SOMA 50 to A22 switch/splitter	1	E8364-20034
W3	A22 switch/splitter to A23 channel R1 detector	1	E8364-20144
W4	A22 switch/splitter to A24 channel R2 detector	1	E8364-20024
W37	A23 channel R1 detector to A16 test set motherboard J204	1	E8364-60121
W38	A24 channel R2 detector to A16 test set motherboard J205	1	E8364-60122
W39	A21 SOMA 50 to A16 test set motherboard J206	1	E8364-60123

Table 1 Option 040 Upgrade Kit (E8362-60109) to Extend the E8362B to 40 GHz

Ref. Desig.	Description	Qty	Part Number
Parts for analyzers WITH NO RF hardware options			
W7	A23 channel R1 detector to A28 channel R1 mixer	1	E8364-20025
W8	A24 channel R2 detector to A29 channel R2 mixer	1	E8364-20026
Parts for analyzers WITH Option UNL ONLY			
W7	A23 channel R1 detector to A28 channel R1 mixer	1	E8364-20174
W8	A24 channel R2 detector to A29 channel R2 mixer	1	E8364-20175
Parts for analyzers WITH Options UNL and 016 ONLY			
W7	A23 channel R1 detector to A28 channel R1 mixer	1	E8364-20149
W8	A24 channel R2 detector to A29 channel R2 mixer	1	E8364-20150

Installation Procedure for the Upgrade Kit

The network analyzer must be in proper working condition prior to installing this option. Any necessary repairs must be made before proceeding with this installation.

WARNING **This installation requires the removal of the analyzer’s protective outer covers. The analyzer must be powered down and disconnected from the mains supply before performing this procedure.**

Electrostatic Discharge Protection

Protection against electrostatic discharge (ESD) is essential while removing or connecting cables or assemblies within the network analyzer.

Static electricity can build up on your body and can easily damage sensitive internal circuit elements when discharged. Static discharges too small to be felt can cause permanent damage. To prevent damage to the instrument:

- *always* wear a grounded wrist strap having a 1 M Ω resistor in series with it when handling components and assemblies.
- *always* use a grounded, conductive table mat while working on the instrument.
- *always* wear a heel strap when working in an area with a conductive floor. If you are uncertain about the conductivity of your floor, wear a heel strap.

Figure 1 shows a typical ESD protection setup using a grounded mat and wrist strap. Refer to “Tools Required for the Installation” on page 7 for part numbers.

Figure 1 **ESD Protection Setup**

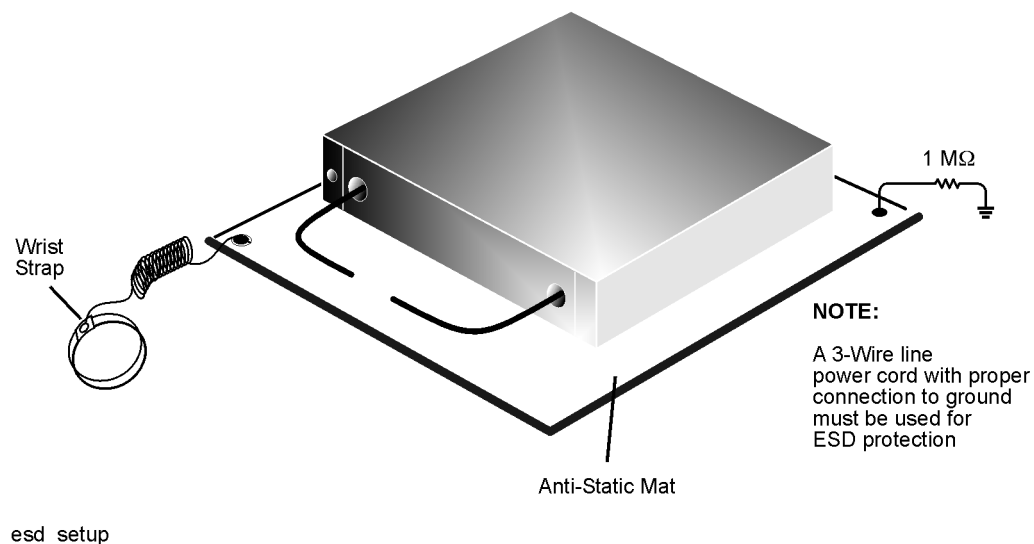

Overview of the Installation Procedure

- Step 1. Verify the Model, Serial, and Option Numbers of the Analyzer
- Step 2. Remove the Outer Cover
- Step 3. Remove the Inner Cover
- Step 4. Remove the Front Panel Assembly
- Step 5. Disconnect the A12 Source 20 to A22 Switch/Splitter Cable at the A12 Source 20
- Step 6. Raise the Receiver Deck
- Step 7. Remove the Old Hardware and Cables
- Step 8. Replace the A38 and A39 Bias Tees (Option UNL Only)
- Step 9. Install the Remaining New Hardware
- Step 10. Install the Remaining Cables
- Step 11. Lower the Receiver Deck
- Step 12. Connect the A12 Source 20 to A21 SOMA 50 Cable at the A12 Source 20
- Step 13. Replace the Front Panel Nameplate
- Step 14. Reinstall the Front Panel Assembly
- Step 15. Reinstall the Inner and Outer Covers
- Step 16. Enter the New Model Number
- Step 17. Verify that the New Model Number Is Shown Correctly
- Step 18. Perform Source and Receiver Calibration Adjustments

Tools Required for the Installation

Description	Agilent Part Number
T-8 TORX driver (set to 5 in-lbs)	N/A
T-10 TORX driver (set to 9 in-lbs)	N/A
T-20 TORX driver (set to 21 in-lbs)	N/A
5/16-inch torque wrench (set to 10 in-lbs)	N/A
1-inch torque wrench (set to 72 in-lbs)	N/A

ESD Equipment and Supplies Required for the Installation

Description	Agilent Part Number
ESD grounding wrist strap	9300-1367
5-ft grounding cord for wrist strap	9300-0980
2 x 4 ft conductive table mat and 15-ft grounding wire	9300-0797
ESD heel strap (for use with conductive floors)	9300-1308

Equipment Required for Post-Installation Adjustments

Equipment Type	Model or Part Number	Alternate Model or Part Number
Power meter	E4418B/E4419B	E4418A/E4419A
Power sensor, 2.4 mm	8487A	None
Adapter, 2.4 mm (f) to 2.4 mm (f)	11900B	85056-60007
RF cable, 2.4 mm (f) to 2.4 mm (f)	85133C	85133E

Step 1. Verify the Model, Serial, and Option Numbers of the Analyzer

Refer to the License Key Certificate supplied with the kit:

- Verify that the analyzer's model and serial numbers match those on the certificate.
- Verify that the option number on the certificate matches the option described by this installation note.

If the model, serial, or option number do not match the expected results, you will not be able to install the option. If this is the case, contact Agilent for assistance. Refer to [“Getting Assistance from Agilent”](#) on page 2.

Step 2. Remove the Outer Cover

CAUTION This procedure is best performed with the analyzer resting on its front handles in the vertical position. *Do not place the analyzer on its front panel without the handles.* This will damage the front panel assemblies.

1. Disconnect the power cord (if it has not already been disconnected).
2. Using a T-20 TORX driver, remove the strap handles (item ①) by loosening the screws (item ②) on both ends until the handle is free of the analyzer.
3. Using a T-20 TORX driver, remove the four rear panel feet (item ③) by removing the center screws (item ④).
4. Slide the four bottom feet (item ⑤) off the cover.
5. Slide the cover off of the frame.

Figure 2 Outer Cover Removal

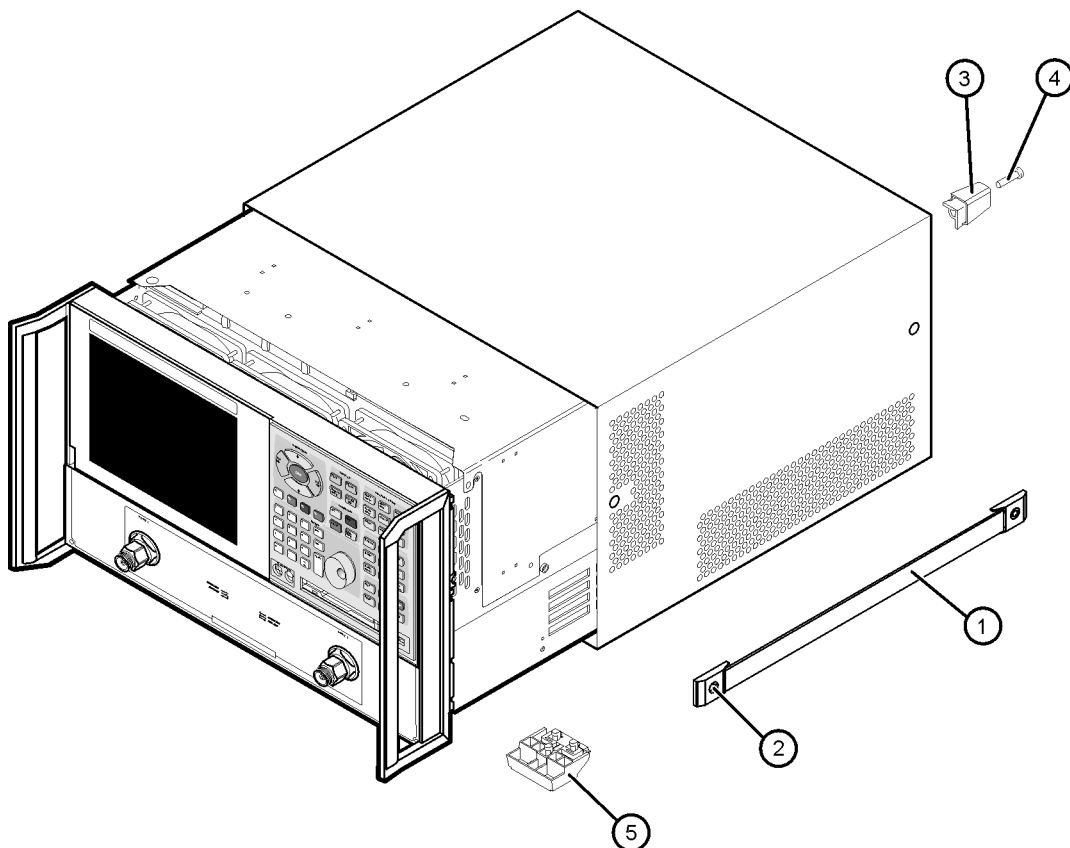

dt501a

Step 3. Remove the Inner Cover

1. Place the analyzer top-side up on a flat surface.
2. Using a T-10 TORX driver, remove the eleven screws (item ①).
3. Lift off the cover.

Figure 3 Inner Cover Removal

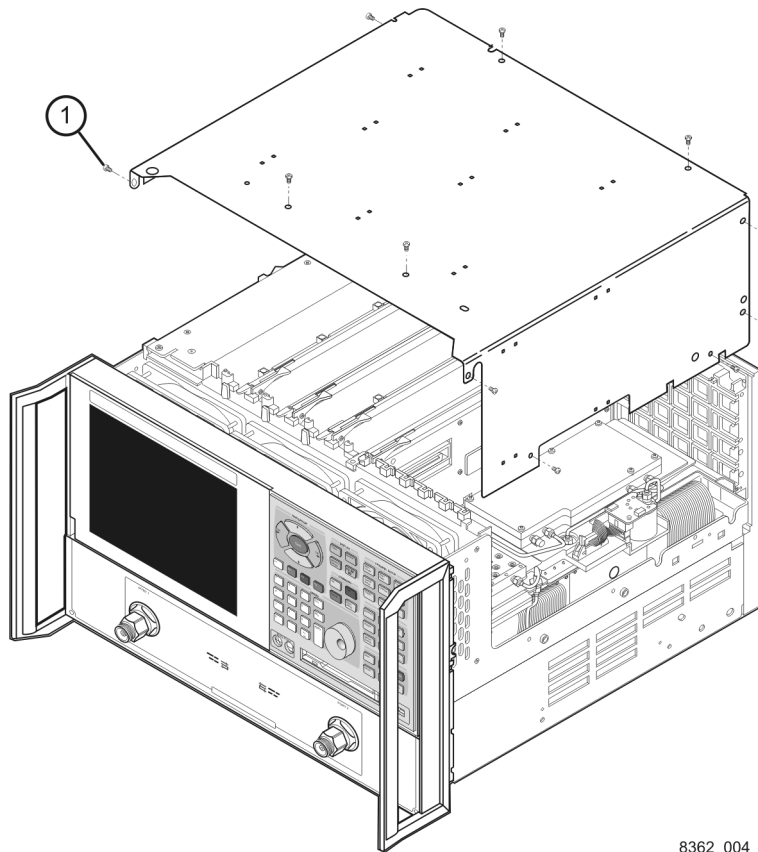

8362_004_01

Step 4. Remove the Front Panel Assembly

1. Using a T-10 TORX driver, remove the eight screws (item ②) from the sides of the frame.

CAUTION Before removing the front panel from the analyzer, lift and support the front of the analyzer chassis.

2. Slide the front panel over the test port connectors.
3. Disconnect the front panel interface ribbon cable (item ③). The front panel is now free from the analyzer.

Figure 4 Front Panel Assembly Removal

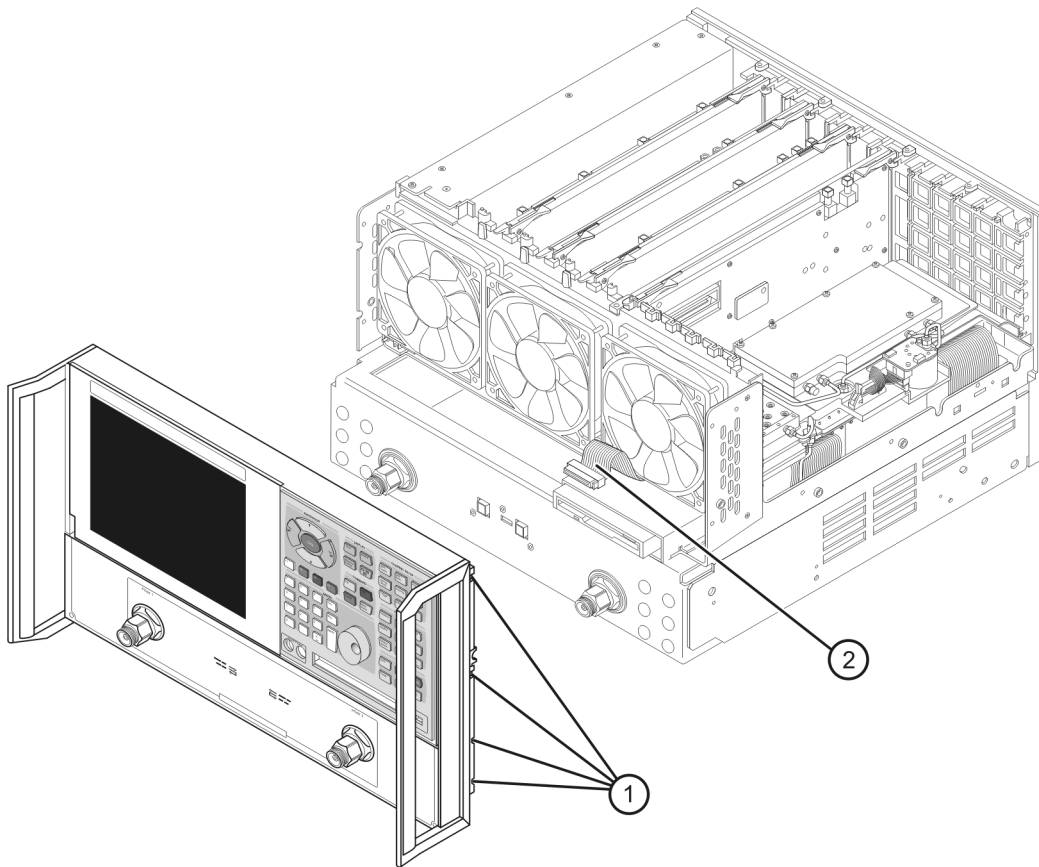

8362_005_02

Step 5. Disconnect the A12 Source 20 to A22 Switch/Splitter Cable at the A12 Source 20

1. Using a 5/16-inch wrench, disconnect the A12 source 20 to A22 switch/splitter cable, W1, at the A12 source 20 as shown.

Figure 5 A12 Source Cable Disconnection

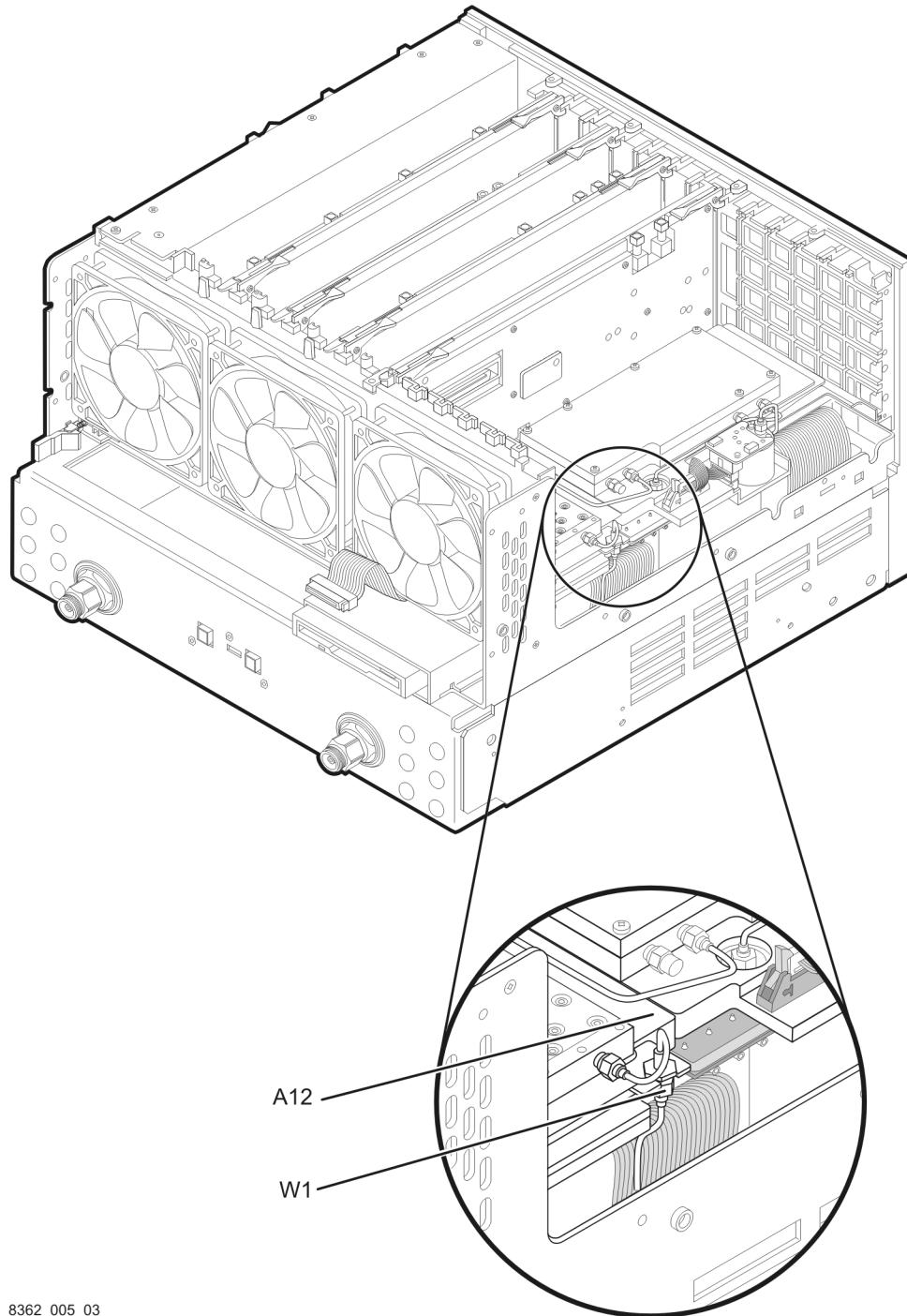

8362_005_03

Step 6. Raise the Receiver Deck

1. Place the analyzer bottom-side up on a flat surface.
2. Using a T-10 TORX driver, remove the four screws, (item ①), that secure the receiver deck.
3. Pull the latch pin (item ②) towards the opposite side of the analyzer to release the receiver deck.
4. Lift the receiver deck to partially raise it, then release the latch pin (item ②). Lift the receiver deck to its fully raised position and ensure that the latch pin latches in the raised position.

Figure 6 Receiver Deck Raising

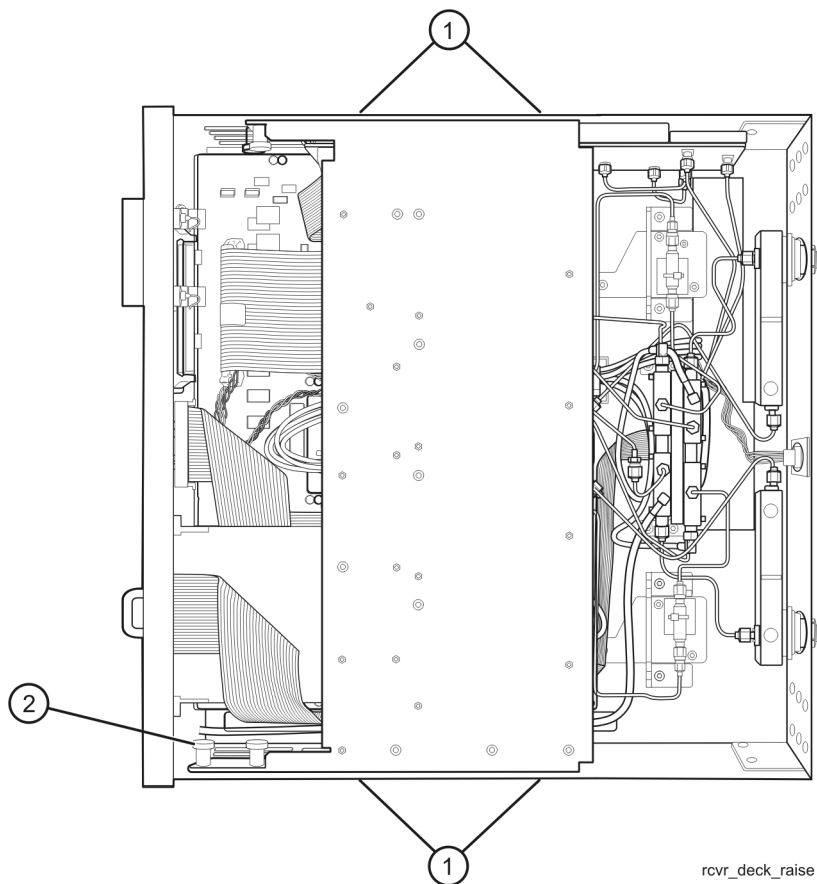

Step 7. Remove the Old Hardware and Cables

Remove the Old Cables (Refer to [Figure 7.](#))

1. Using a 5/16-inch wrench, remove the following cables in the order listed.
 - W1 A12 source 20 to A22 switch splitter
 - W3 A22 switch splitter to channel R1 fixed attenuator
 - W4 A22 switch splitter to channel R2 fixed attenuator
 - W7 Channel R1 fixed attenuator to A28 channel R1 mixer
 - W8 Channel R2 fixed attenuator to A29 channel R2 mixer

Remove the Fixed Attenuators (Refer to [Figure 7.](#))

2. Cut the cable ties (item ①).
3. Remove the attenuators (item ②) from the analyzer.
4. Remove the adhesive clamps (item ③) by sliding a thin, sharp blade under the clamp and lifting. Scrape away any excess adhesive from the bracket.

Replace the A27 and A30 Mixers (Refer to [Figure 7](#) and [Figure 8.](#))

5. Disconnect all RF cables (item ④) from the mixers.
6. Remove two RF cables (item ⑤) from the analyzer and retain for reinstallation later.
7. Remove four screws (item ⑥) from the mixer bracket. Retain the screws for reinstallation later.
8. Remove the mixer bracket, with the mixers attached, from the analyzer. Observe the **CAUTION** below. Disconnect the ribbon cable to allow the mixer bracket to be removed.

CAUTION Be careful not to damage the center pins of the semirigid cables. Some flexing of the cables is necessary when removing the assemblies. Do not over-bend them.

9. Remove the old A27 and A30 mixers from the mixer bracket by removing three screws from each, as shown in [Figure 8](#). Retain the screws to install the new mixers.
10. Install the new A27 and A30 mixers using the screws removed from the old mixers. Be sure to orient the mixers as shown in [Figure 8](#).
11. Reconnect the ribbon cable and place the mixer bracket, with all four mixers attached, into the analyzer. Observe the **CAUTION** above.
12. Reinstall the four screws (item ⑥) to secure the bracket.
13. Reconnect all RF cables (item ⑤) to the mixers.

Figure 7 Mixers Bracket Removal

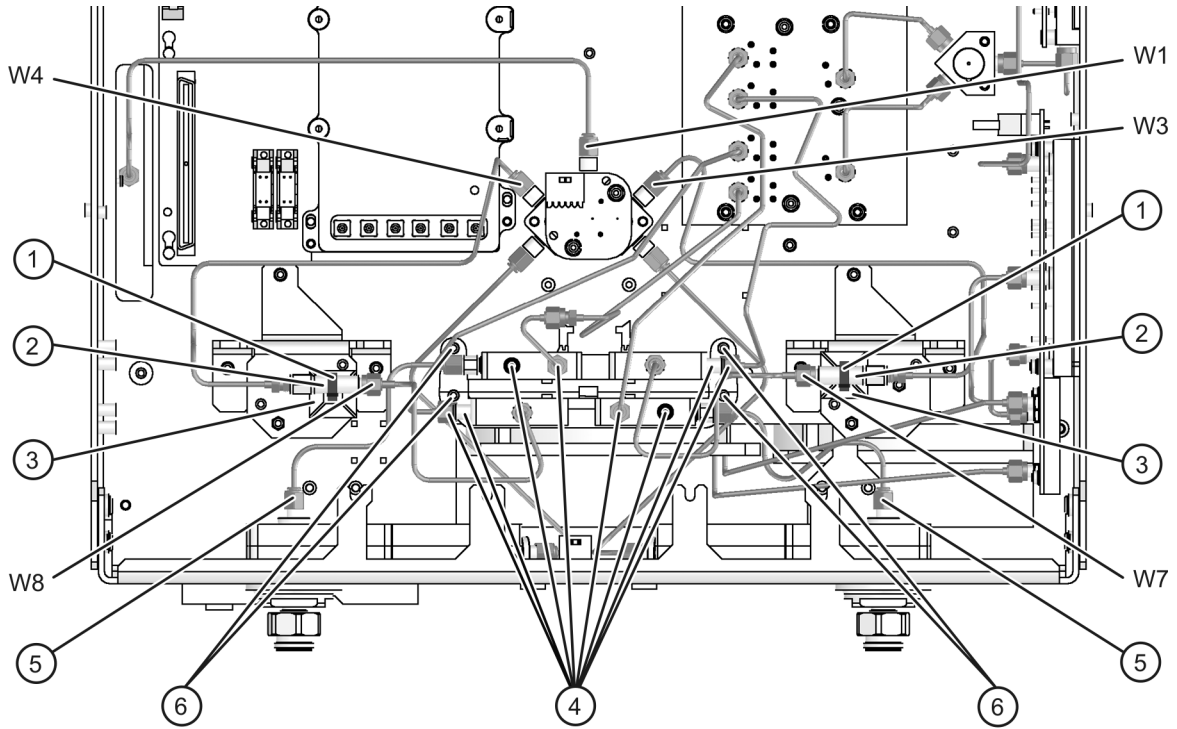

8362_004_05

Figure 8 Mixers Replacement

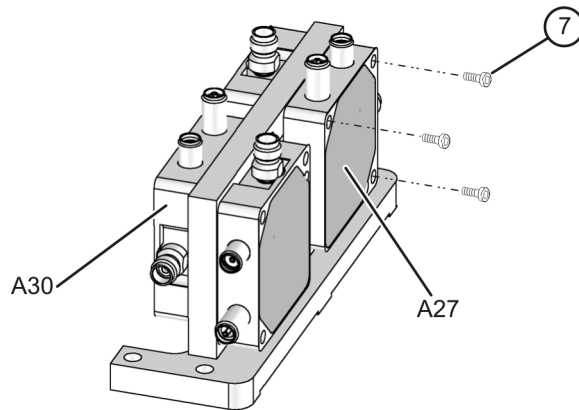

8362_005_06

Replace the Test Set Deck Front Panel and the A25 and A26 Test Port Couplers

Remove the Existing Test Set Deck Front Panel (Refer to [Figure 9](#).)

1. Disconnect the wrapped wire cable (item ①) from the front-panel LED board.
2. Disconnect the remaining RF cable (item ②) from each test port coupler.
3. Using a T-10 TORX driver, remove eight screws (items ① through ⑧) from the test set deck front panel, to release it.
4. Remove the test set deck front panel from the analyzer, with the LED board and both couplers attached.
5. Using a 1-inch wrench, remove the flange nut (item ③) from each coupler. Retain the flange nuts for installation of the new couplers. Discard the front panel and the couplers.

Figure 9 Test Set Deck Front Panel Replacement

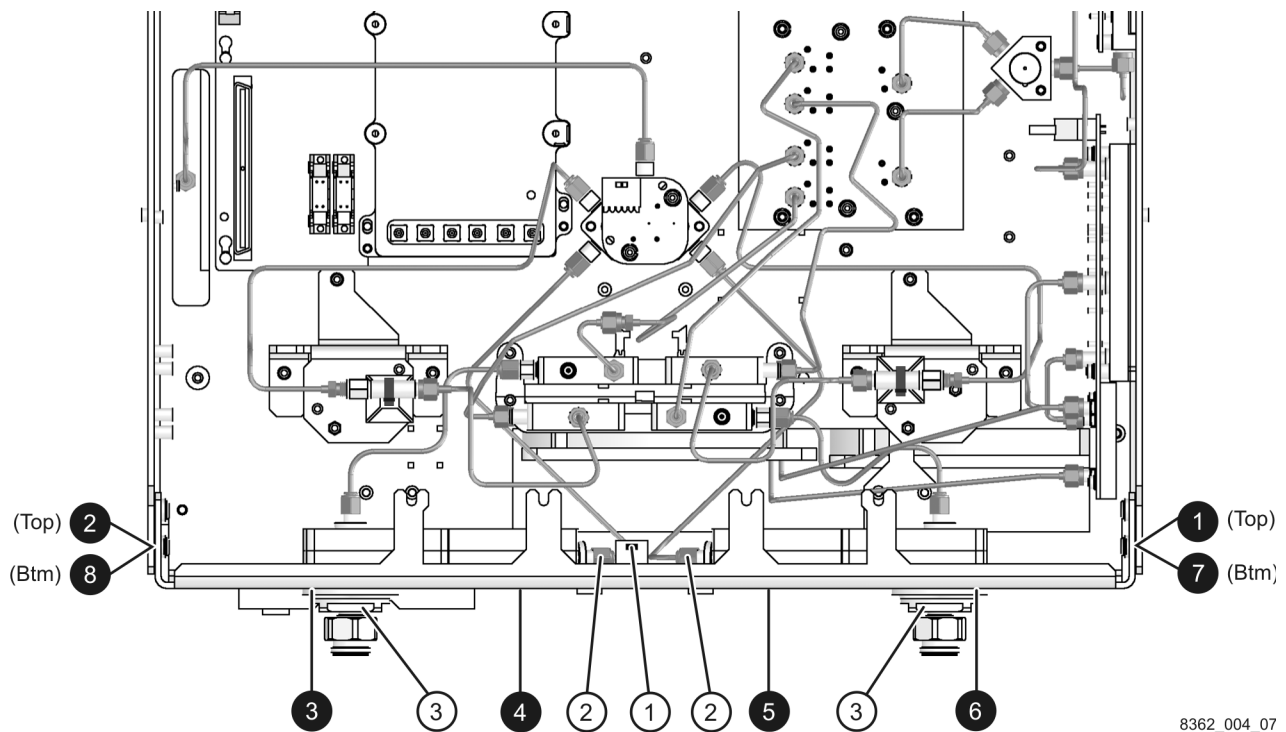

Install the Old Front Panel LED Board onto the New Front Panel (Refer to [Figure 10.](#))

1. Remove the LED board from the old front panel by removing the three retaining screws (item ①).
2. Place the LED board in position on the new front panel and attach it with the three screws (item ①) removed from the old front panel.

Figure 10 Front Panel LED Board Reinstallation

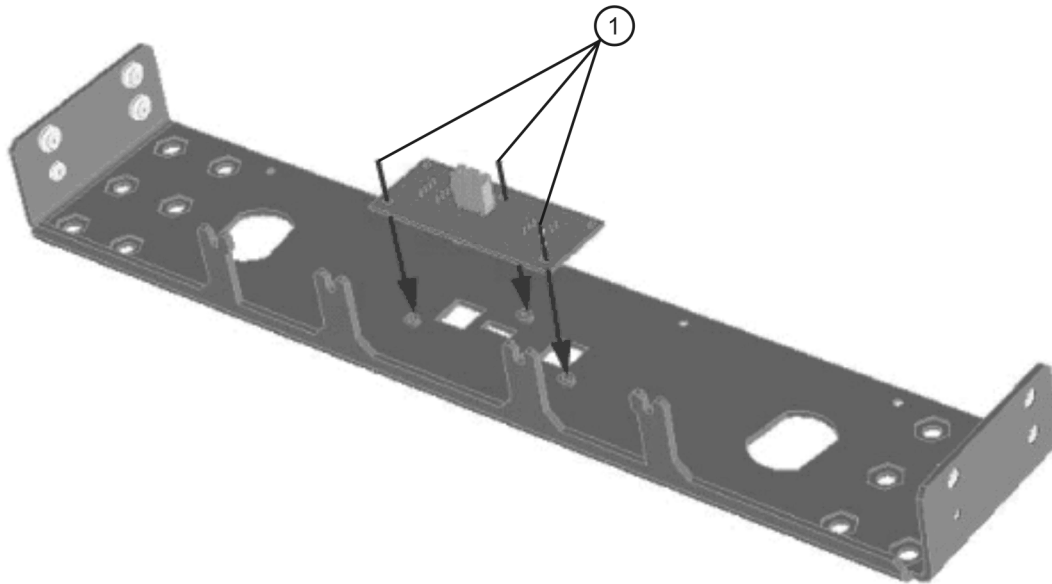

8362_005_08

Install the New Couplers on the New Front Panel (Refer to [Figure 9.](#))

1. Place the new couplers onto the new front panel. Orient them the same as the old ones as shown in [Figure 9.](#)
2. Install a flange nut (item ③) removed from the old couplers, onto each new coupler. Using a 1-inch torque wrench, tighten each flange nut to 72 in-lbs.
3. Reconnect the two cables (item ②) to the test port couplers that were disconnected on [page 16.](#)

Install the New Front Panel on the Analyzer (Refer to [Figure 9.](#))

1. Place the new test set deck front panel, with the new LED board and both new couplers attached, onto the test set deck as shown in [Figure 9.](#)
2. Using a T-10 TORX driver, *loosely* reinstall the eight screws (items ① through ⑧) to secure the front panel to the test set deck. Torque each of the eight screws to 9 in-lbs in the order indicated (① through ⑧). This is important to ensure proper alignment.
3. Reconnect the wrapped wire cable (item ①) to the front-panel LED board.

Step 8. Replace the A38 and A39 Bias Tees (Option UNL Only)

Remove the Detector/Bias Tee/Attenuator Brackets (Refer to Figure 11.)

1. Disconnect all remaining RF cables from each attenuator (item ①) and bias tee (item ②).
2. Disconnect the bias tee control cables at the A16 test set motherboard connectors, J22 (P1 BIAS T) and J25 (P2 BIAS T), and release them from the cable clamp (item ③).
3. Disconnect the ribbon cables at the step attenuators (item ①).
4. Remove three screws (item ④) from each bracket. Retain the screws for reinstallation.
5. Remove the brackets, with the attenuators and bias tees attached, from the analyzer.

CAUTION Be careful not to damage the center pins of the semirigid cables. Some flexing of the cables is necessary when removing the assemblies. Do not over-bend them.

Figure 11 Detector/Bias Tee/Attenuator Brackets Removal

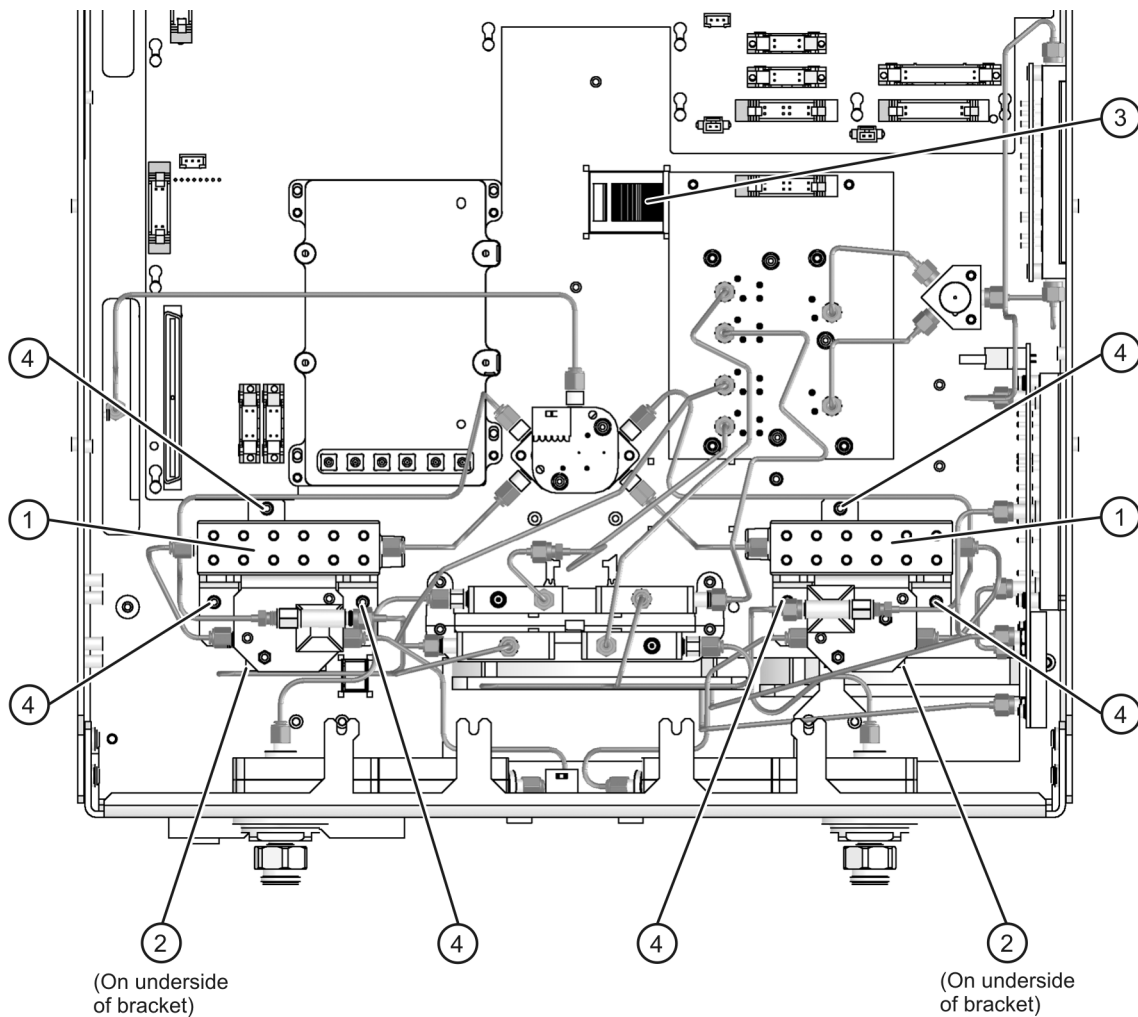

8362_004_09

Replace the Bias Tees (Refer to [Figure 12](#).)

1. Remove the old bias tees from the bracket by removing two screws (item ①) from each. Retain the screws for installing the new bias tees.
2. Install the new bias tees using the screws (item ①) removed from the old bias tees. Be sure to install the ground lug (item ②) over the attachment screw as shown.

Figure 12 Bias Tees Replacement

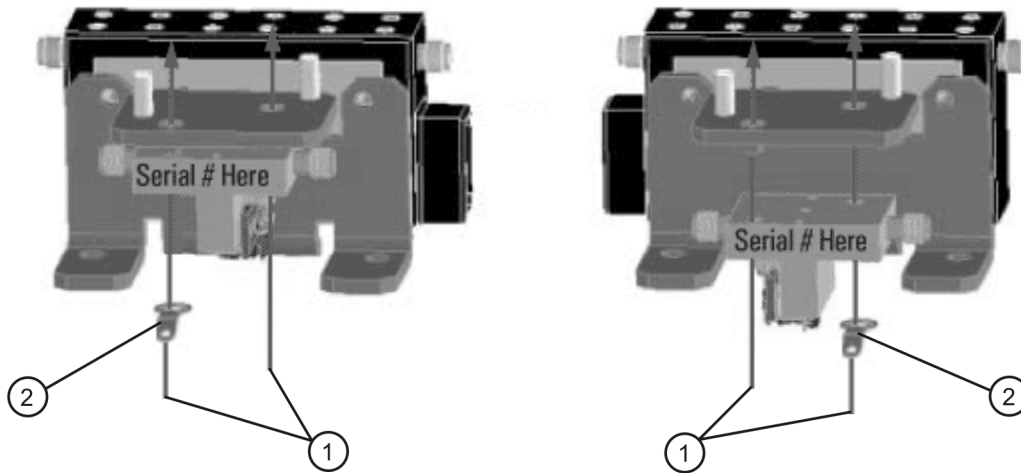

8362_005_10

Reinstall the Detector/Bias Tee/Attenuator Brackets (Refer to [Figure 11](#).)

1. Place the brackets, with the attenuators and bias tees attached, into the analyzer as shown in [Figure 11](#).
2. Reinstall the three screws (item ④) in each bracket.
3. Reconnect the ribbon cables to the attenuators (item ①).
4. Reconnect the bias tee control cables to the A16 test set motherboard. The A38 cable connects to J22 (P1 BIAS T) and the A39 cable connects to J25 (P2 BIAS T). Be sure to route them under the cable clamp, (item ③).
5. Reconnect all RF cables to the attenuators (item ①) and bias tees (item ②).

Step 9. Install the Remaining New Hardware

Install the A23 and A24 Detectors (Refer to [Figure 13](#).)

1. Place the A23 and A24 detectors on top of the brackets in the analyzer. Be sure to orient them as shown.
2. Install two screws (item ①) in each detector to secure them to the brackets.
3. Connect the wrapped wire control cables from the A23 and A24 detectors:
 - A23 detector to A16 test set motherboard J5 (R1 DET)
 - A24 detector to A16 test set motherboard J6 (R2 DET)

Install the A21 SOMA 50 (Refer to [Figure 13](#).)

1. Place the A21 SOMA 50 in position in the analyzer. Be sure to orient it as shown.
2. Install four screws (item ②) to secure the SOMA 50 to the A16 test set motherboard.
3. Connect the A21 SOMA 50 ribbon cable to A16 test set motherboard J4 (SOMA50).

Figure 13 A23 and A24 Detectors and A21 SOMA 50 Installation

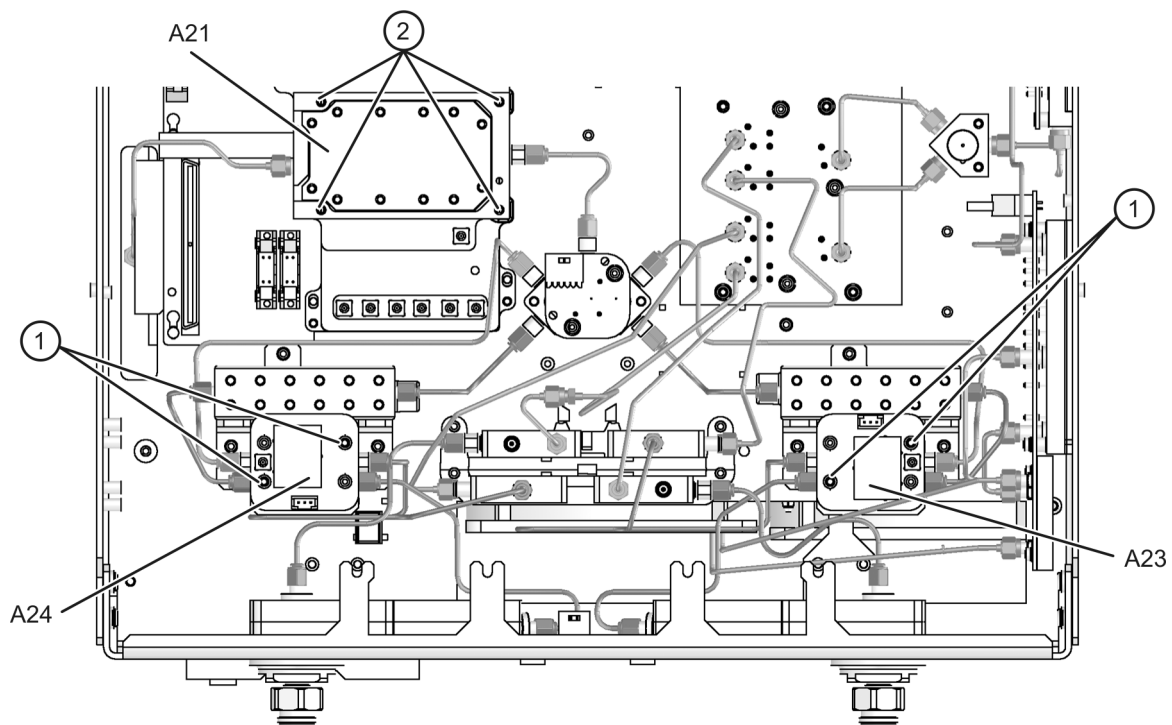

8362_005_11

Step 10. Install the Remaining Cables

Using a 5/16-inch torque wrench set to 10in-lbs, install the following new cables **in the order listed**. These new parts are listed in [Table 1 on page 4](#).

- W1 A12 source 20 to A21 SOMA 50
Connect this cable to the A21 SOMA 50 connector as shown with the other end of the cable routed through the opening to the top side of the analyzer. The other end of this cable will be connected later.
- W2 A21 SOMA 50 to A22 switch/splitter
- W3 A22 switch/splitter to A23 channel R1 detector
- W4 A22 switch/splitter to A24 channel R2 detector
- W37 A23 channel R1 detector to A16 test set motherboard J204 (R1)
- W38 A24 channel R2 detector to A16 test set motherboard J205 (R2)
- W39 A21 SOMA 50 to A16 test set motherboard J206 (SOMA 50)
- W7 A23 channel R1 detector to A28 channel R1 mixer
The shape of this cable varies depending upon the option installed. Be sure to install the correct cable for your analyzer as specified in [Table 1 on page 4](#).
- W8 A24 channel R2 detector to A29 channel R2 mixer
The shape of this cable varies depending upon the option installed. Be sure to install the correct cable for your analyzer as specified in [Table 1 on page 4](#).

Figure 14 Cables Installation

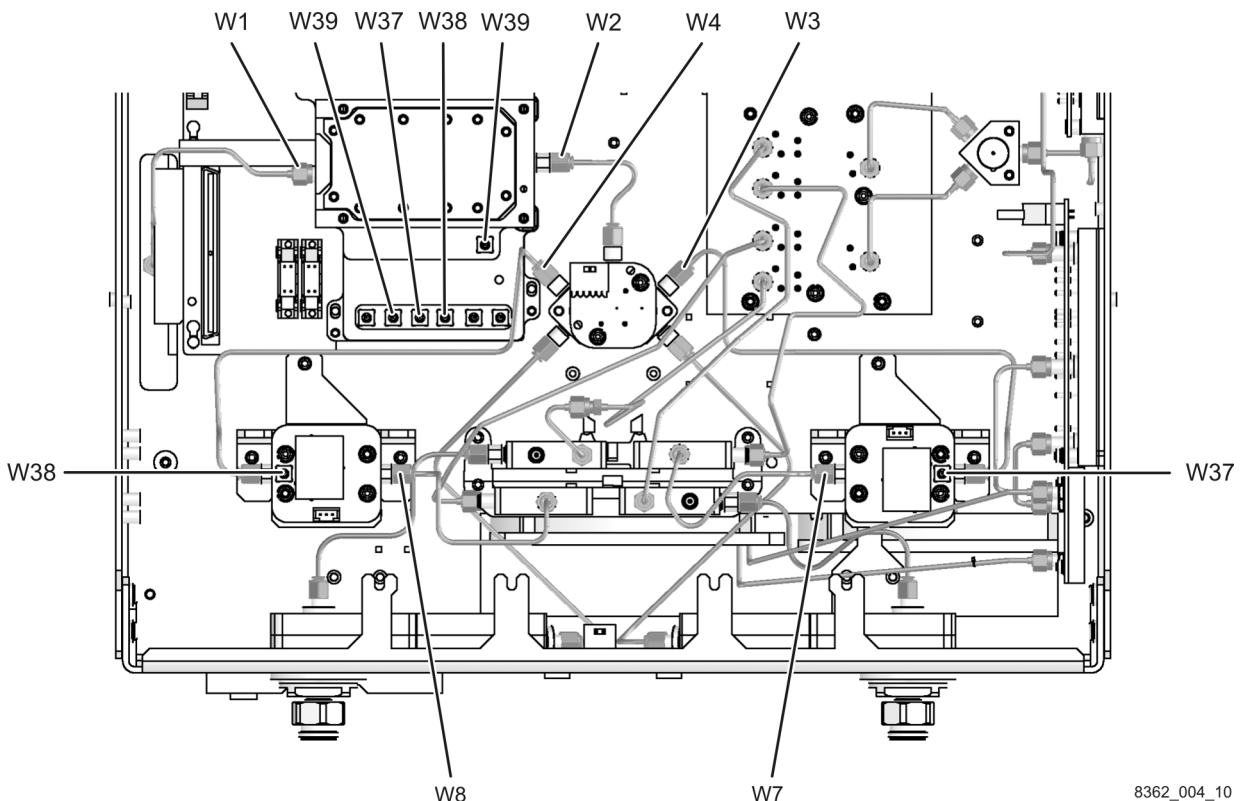

8362_004_10

Step 11. Lower the Receiver Deck

1. Pull the latch pin (item ②) towards the opposite side of the analyzer to release the receiver deck.
2. Lift the receiver deck to partially lower it, then release the latch pin (item ②). Lower the receiver deck to its fully lowered position and ensure that the latch pin latches in the lowered position.
3. Using a T-10 TORX driver, reinstall the four screws, (item ①), to secure the receiver deck.

Figure 15 Receiver Deck Lowering

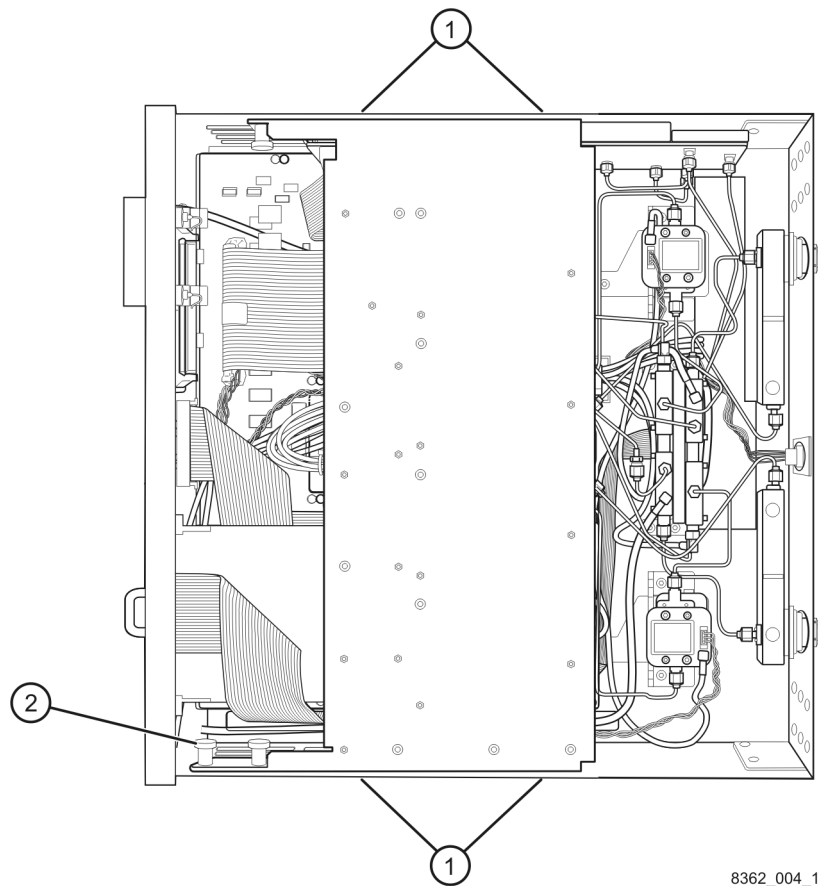

8362_004_13

Step 12. Connect the A12 Source 20 to A21 SOMA 50 Cable at the A12 Source 20

1. Place the analyzer top-side up on a flat surface.
2. Using a 5/16-inch wrench, connect the A12 source 20 to A21 SOMA 50 cable, W1, at the A12 source 20 as shown.

Figure 16 A12 Source Cable Connection

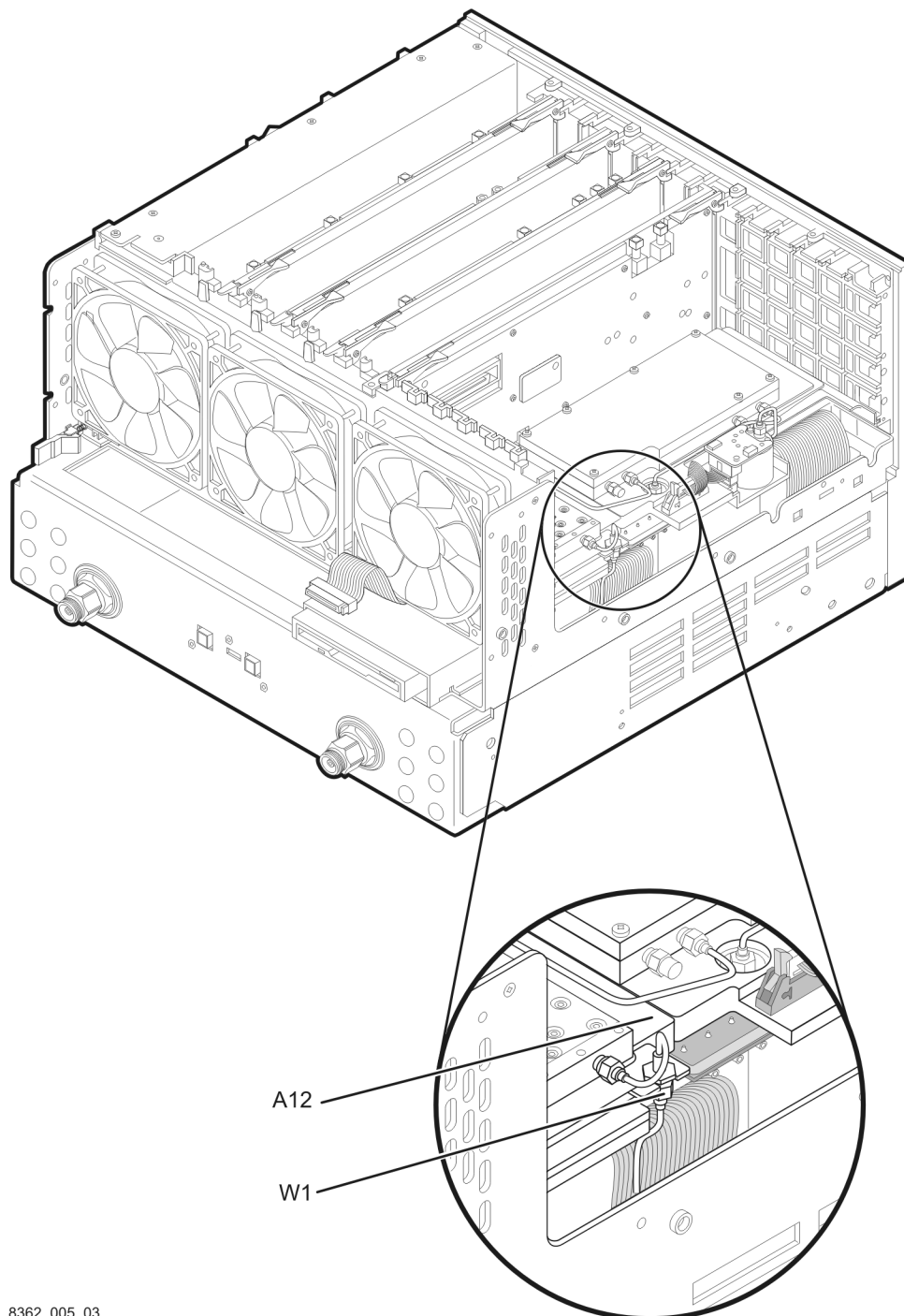

8362_005_03

Step 13. Replace the Front Panel Nameplate

Remove the Old Nameplate

1. Using a sharp object such as a knife blade, lift one end of the old nameplate (item ①). Be careful not to scratch the painted surface.
2. Using your fingers, pull the nameplate completely off of the front panel and discard it.
3. If any adhesive remains on the front panel surface, it can be removed by rubbing it with your finger. Do not use a sharp object to remove this adhesive. If necessary, the surface can be cleaned with isopropyl alcohol.

Install the New Nameplate

IMPORTANT If the Option 050 upgrade kit will be installed to extend the frequency to 50 GHz, do not install the new nameplate provided in this upgrade kit. Instead, use the one provided in the Option 050 upgrade kit.

1. Remove the protective backing from the new nameplate to expose the adhesive. Avoid touching the adhesive with your fingers as this may affect its ability to adhere to the front panel surface.
2. *Loosely* align the new nameplate over the recess in the front panel and apply lightly.
3. Once the nameplate is properly aligned, press it firmly onto the surface to secure it.

Figure 17 Model Number Nameplate Replacement

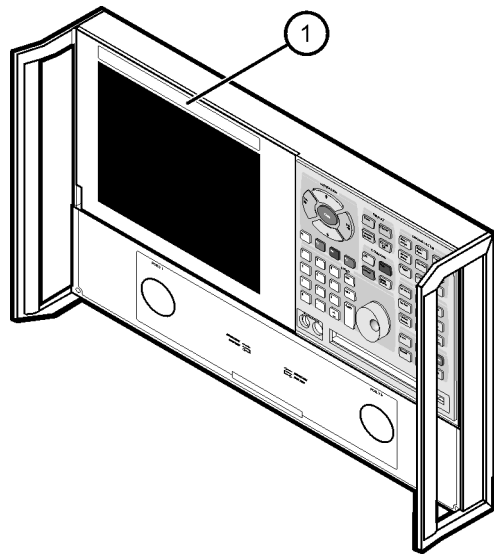

8363_001_01

Step 14. Reinstall the Front Panel Assembly

CAUTION Before installing the front panel assembly onto the analyzer, lift and support the front of the analyzer chassis.

1. Reconnect the ribbon cable (item ①) to the A3 front panel interface board.
2. Slide the front panel over the test port connectors being careful to align the power switch and floppy disk drive to their corresponding front panel cutouts. Ensure that the ribbon cable (item ①) is located below the fan to prevent it from being damaged by the fan blades.
3. Using a T-10 TORX driver, install the eight screws (item ②) in the sides of the frame.

Figure 18 Front Panel Assembly Reinstallation

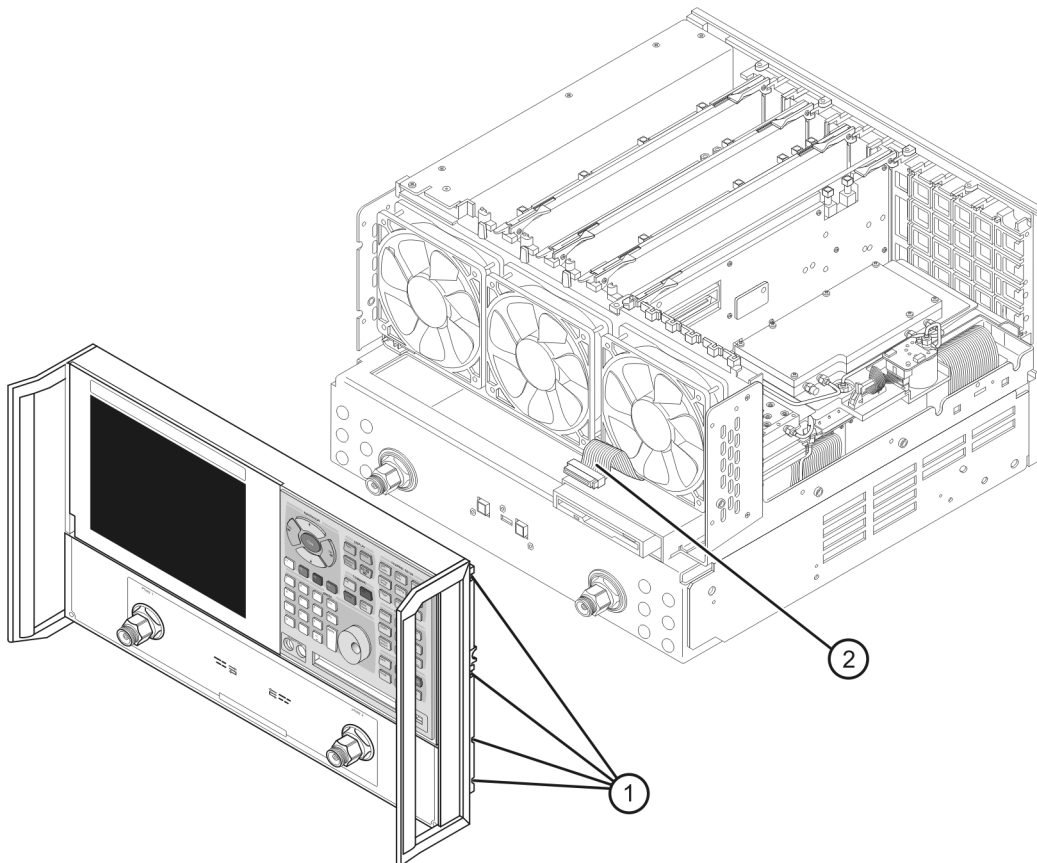

8362_005_02

Step 15. Reinstall the Inner and Outer Covers

Reinstall the Inner Cover

1. Place the inner cover on the analyzer as shown. There are two alignment pins on the front frame that align with holes in the front of the cover to ensure proper alignment.
2. Using a T-10 TORX driver, reinstall the eleven screws (item ①).

Figure 19 Inner Cover Reinstallation

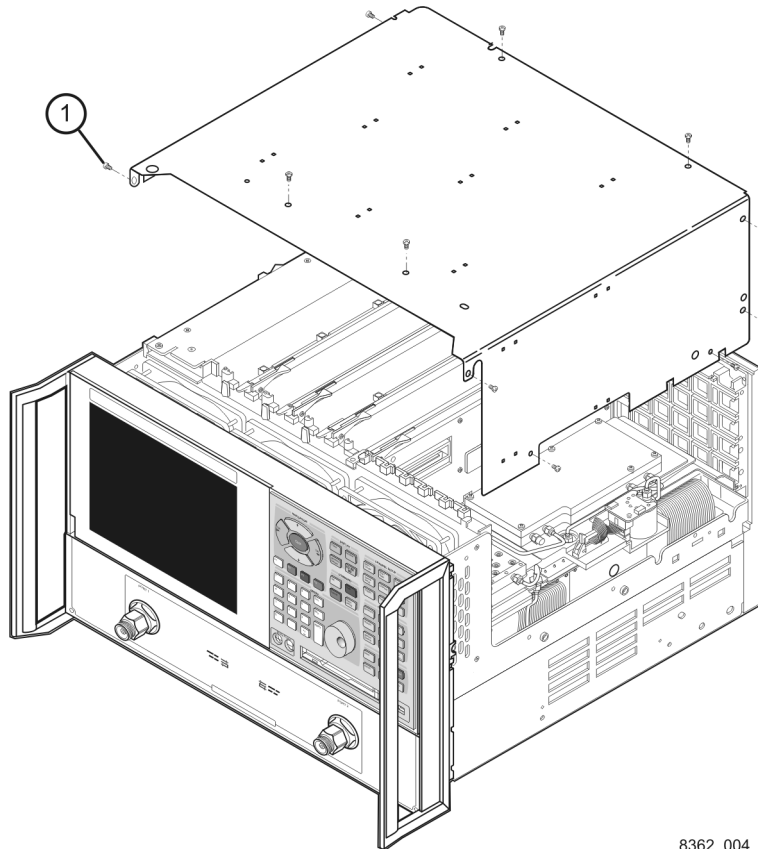

8362_004_01

Reinstall the Outer Cover

CAUTION This procedure is best performed with the analyzer resting on its front handles in the vertical position. *Do not place the analyzer on its front panel without the handles.* This will damage the front panel assemblies.

1. Slide the cover onto the frame.
2. Using a T-20 TORX driver, install the four rear panel feet (item ③) by installing the center screws (item ④).
3. Slide the four bottom feet (item ⑤) onto the cover.
4. Using a T-20 TORX driver, install the strap handles (item ①) by tightening the screws (item ②) on both ends.

Figure 20 Outer Cover Reinstallation

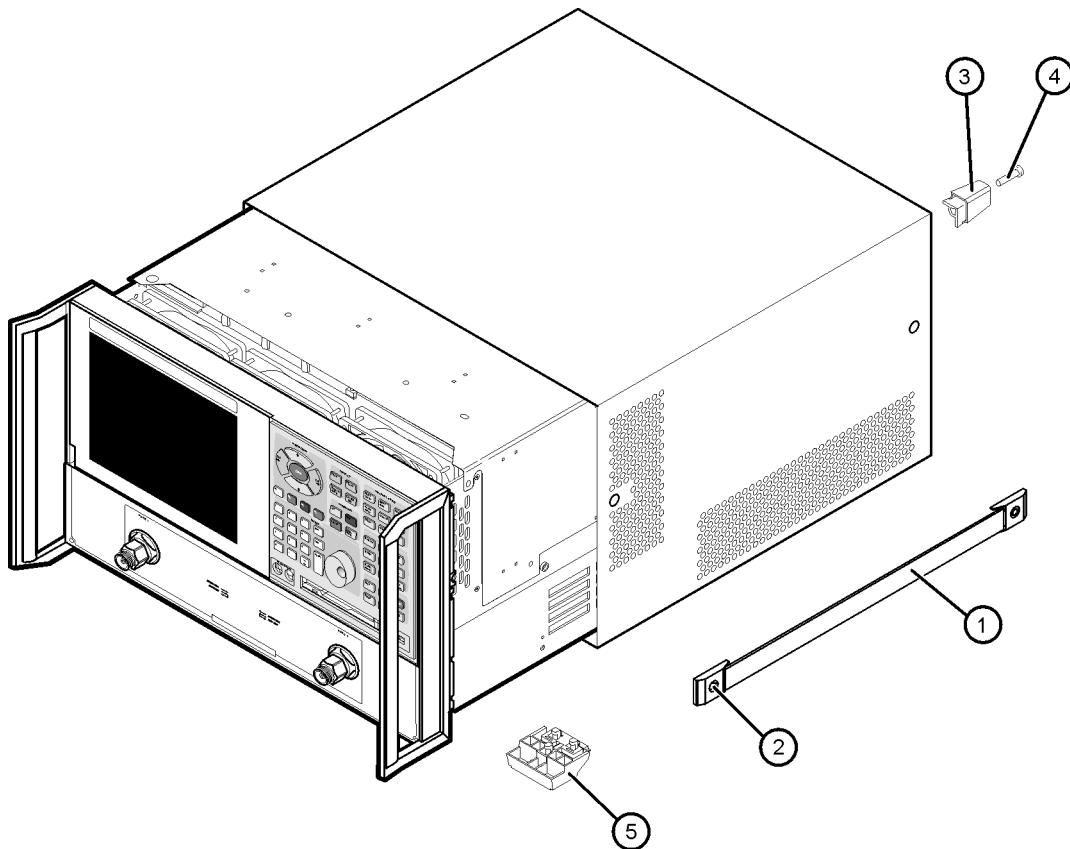

dt501a

Step 16. Enter the New Model Number

Procedure Requirements

- The analyzer must be powered up and operating to perform this procedure.
- The Network Analyzer program must be running.
- A keyboard is required for this procedure.
- A mouse is recommended for this procedure but is not required.

Mouse Procedure

1. On the analyzer's **System** menu, point to **Service**, then click **Option Enable**.
2. Click **Repair**.
3. Check **Model shown is incorrect!**, then click **Begin Repair**.
4. In the **Model Change** box, select the new model number, **E8363B**.
5. Using the keyboard, enter the keyword in the box provided. The keyword is printed on the License Key Certificate. Enter this keyword *exactly* as it is printed on the certificate.
6. Click **Enter Model**.
7. Verify that the new model number displayed is correct, then click **YES**. If it is not correct, click **NO** and repeat the repair.
8. When the installation is complete, click **Exit**.

Front Panel Keys Procedure

1. In the **COMMAND** block, press **Menu/Dialog**.
2. In the **NAVIGATION** block, press the right tab and arrow keys to move over to the **System** menu and down to the **Service** selection. Press the right tab to display the extended menu and the arrows to select **Option Enable**. Press **Click**.
3. Press **Menu/Dialog**, then press **R** on the keyboard to select **Repair**.
4. Tab to **Model shown is incorrect!**, then press **Click**.
5. Tab to the **Model Change** box, then use the arrows to select the new model number, **E8363B**.
6. Tab to the **Keyword** box and, using the keyboard, enter the keyword. The keyword is printed on the License Key Certificate. Enter this keyword *exactly* as it is printed on the certificate.
7. Tab to **Enter Model**, then press **Click**.
8. Verify that the new model number displayed is correct, then tab to **Yes** and press **Click**. If it is not correct, tab to **NO**, press **Click**, and repeat the repair.
9. When the installation is complete, Tab to **Exit**, then press **Click**.

Step 17. Verify that the New Model Number Is Shown Correctly

Procedure Requirements

- The analyzer must be powered up and operating to perform this procedure.
- The Network Analyzer program must be running.
- A mouse is recommended for this procedure but is not required.

Mouse Procedure

1. On the analyzer's **Help** menu, click **About Network Analyzer**.
2. Verify that the new model number, E8363B, is shown correctly in the display. Click **OK**.
3. On the analyzer front panel, press **Preset**. Verify that the full frequency range of the analyzer is correct. The analyzer should preset to a frequency range of 10 MHz to 40 GHz.

Front Panel Keys Procedure

1. In the **COMMAND** block, press **Menu/Dialog**.
2. In the **NAVIGATION** block, press the right tab and arrow keys to move over to the **Help** menu, and down to the **About Network Analyzer** selection. Press **Click**.
3. Verify that the new model number, E8363B, is shown correctly, then press **Click**.
4. On the analyzer front panel, press **Preset**. Verify that the full frequency range of the analyzer is correct. The analyzer should preset to a frequency range of 10 MHz to 40 GHz.

Step 18. Perform Source and Receiver Calibration Adjustments

The following adjustments must be made due to the change in the full frequency range of the analyzer.

- source calibration
- receiver calibration

These adjustments are described in the PNA service guide and in the PNA on-line HELP. A list of equipment required to perform these adjustments can be found at [“Tools Required for the Installation” on page 7](#).

Performance Tests and System Verification

The analyzer should now operate and phase lock over its entire frequency range.

If you experience difficulty with the basic functioning of the analyzer, contact Agilent. Refer to [“Getting Assistance from Agilent” on page 2](#).

Although the analyzer functions, its performance relative to its specifications has not been verified for the additional frequency range enabled by this upgrade.

It is recommended that a full instrument calibration be performed using the N2721A performance test software.

If the testing of the analyzer’s full range of specifications is not required, a system verification can be performed.

Refer to the analyzer’s service guide for information on performance tests and system verification.